

## Modular Cooking Range Line EVO700 Gas Solid Top with 2 Burners

ITEM # \_\_\_\_\_

MODEL # \_\_\_\_\_

NAME # \_\_\_\_\_

SIS # \_\_\_\_\_

AIA # \_\_\_\_\_



372011 (Z7STGH3000)

Gas solid top (3,8 kW) with 2  
burners (5,5 kW each), full  
module

### Short Form Specification

**Item No.** \_\_\_\_\_

High efficiency 3.8 kW central burner, flame failure device and protected pilot light. Suitable for natural gas or LPG. Large cooking surface with different heating zones. Large flat cooking surface made in cast iron allows for the use of a number of various sized pots and pans, all easily moved across the surface without lifting. Two high efficiency 5,5 kW flower flame burners with continuous power regulation and protected pilot light interchangeable on site. Flame failure device as standard on burners to protect against accidental extinguishing. Exterior panels in stainless steel with Scotch Brite finish. One piece pressed work top in 1.5 mm thick stainless steel. Right-angled side edges to allow flush-fitting junction between units.

### Main Features

- Gas heated, 3.8 kW central burner, solid top.
- Durable cast iron cooking plate, easy to clean.
- The center of the plate can reach a maximum temperature of 500 °C while decreasing outwards.
- Central burner with optimized combustion, flame failure device and protected pilot light.
- Temperature gradients to satisfy different cooking needs, provided over the whole plate thanks to the temperature fine-tuning by zone.
- Various sizes of pans can be used at the same time due to large surface area with no intermediate sectors.
- Pans can easily be moved from one area to another without lifting.
- Burners with optimized combustion interchangeable on site.
- Flame failure device on each burner protects against gas leakage when accidental extinguishing of the flame occurs.
- All major compartments located in front of unit for ease of maintenance.
- Suitable for countertop installation.

### Construction

- All exterior panels in Stainless Steel with Scotch Brite finishing.
- One piece pressed 1.5 mm work top in Stainless steel.
- Model has right-angled side edges to allow flush fitting joints between units, eliminating gaps and possible dirt traps.
- IPx4 water protection.

APPROVAL: \_\_\_\_\_

**Optional Accessories**

- Junction sealing kit PNC 206086
- Support for bridge type installation, 800 mm PNC 206137
- Support for bridge type installation, 1000 mm PNC 206138
- Support for bridge type installation, 1200 mm PNC 206139
- Support for bridge type installation, 1400 mm PNC 206140
- Support for bridge type installation, 1600 mm PNC 206141
- Frontal handrail 800 mm PNC 206167
- Large handrail (portioning shelf) 800 mm PNC 206186
- Frontal handrail 1200 mm PNC 206191
- Frontal handrail 1600 mm PNC 206192
- Right and left side handrails PNC 206240
- Single burner smooth plate for direct cooking - fits frontal burners only PNC 206260
- Single burner ribbed plate for direct cooking- fits frontal burners only PNC 206261
- Single burner radiant plate for pan support PNC 206264
- Water column with swivel arm (water column extension not included) PNC 206289
- Water column extension PNC 206291
- Stainless steel grid for 2 burners PNC 206297
- Chimney upstand, 800 mm PNC 206304
- 2 side covering panels, height 250 mm, depth 700 mm PNC 206320
- Wok pan support for open burners (EVO700/900) PNC 206363
- Kit town gas nozzles (G150) for EVO700 solid top and burner PNC 206388
- Chimney grid net, 400mm PNC 206400
- Kit G.25.3 (NI) gas nozzles for 700 solid top and solid top combined with burners PNC 206461
- Pressure regulator for gas units PNC 927225

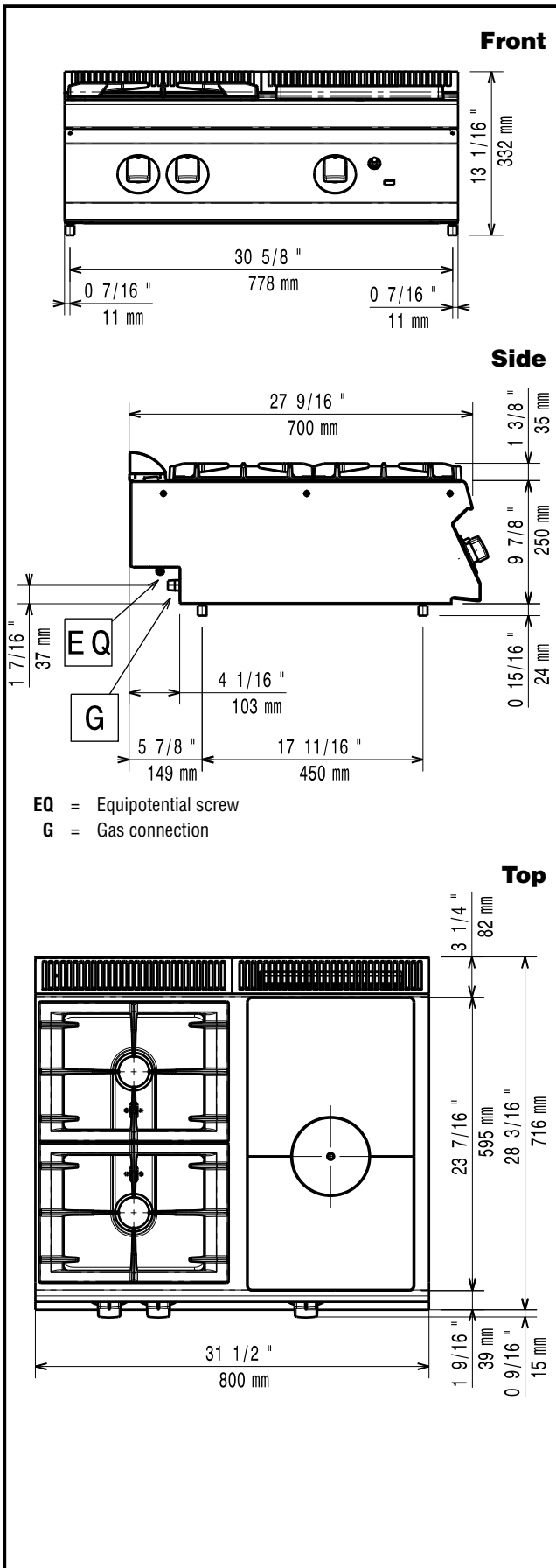

**Gas**

Gas Power:	14.6 kW
Standard gas delivery:	Natural Gas G20 (20mbar)
Gas Type Option:	LPG
Gas Inlet:	1/2"

**Key Information:**

If appliance is set up or next to or against temperature sensitive furniture or similar, a safety gap of approximately 150 mm should be maintained or some form of heat insulation fitted.

External dimensions, Width:	800 mm
External dimensions, Depth:	700 mm
External dimensions, Height:	250 mm
Net weight:	55 kg
Shipping weight:	56 kg
Shipping height:	540 mm
Shipping width:	820 mm
Shipping depth:	860 mm
Shipping volume:	0.38 m <sup>3</sup>
Front Burners Power:	5.5 - kW
Back Burners Power:	5.5 - 0 kW
Certification group:	N7TG
Back Burners Dimension - mm	Ø 60
Front Burners Dimension - mm	Ø 60
Solid top usable surface (width):	340 mm
Solid top usable surface (depth):	595 mm